



Seagate Neighborhood Plan



City of Wilmington Development Services

Adopted by the Wilmington City Council

July 10, 2007



Seagate Neighborhood Plan

Adopted by City Council

July 10, 2007

Wilmington City Council

Bill Saffo, Mayor

Jim Quinn, Mayor Pro-Tem

Pat Delair

Lethia Hankins

Laura Padgett

Earl Sheridan

Jason Thompson

City Manager

Sterling Cheatham

Development Services Department, Planning Division

Kaye Graybeal, Interim Development Services Director

Ron Satterfield, Acting Planning Manager

Christine Hughes, Senior Planner

Brian Chambers, Associate Planner

Corey Taylor, Associate Planner

Lawless Bean, TDM Coordinator

John Fullerton, Zoning Administrator

Mike Kozlosky, Senior Planner

Joshuah Mello, Associate Planner

Phil Prete, Environmental Planner

Jeff Walton, Associate Planner

Misty Watkins, Associate Planner

Kathryn Hoffman, Intern

The Seagate Neighborhood Plan is available from the City of Wilmington Development Services Department, 305 Chestnut Street, PO Box 1810, Wilmington, NC 28402, or by calling 910.254.0900.

Cover photos, clockwise from left: cottage on Greenville Avenue, Salt Works on Oleander Drive, Bradley Creek Bridge (Oleander Drive), The Moorings



Table of Contents

Introduction

Methodology

Boundaries

Seagate History

Existing Conditions

 Future Land Use Plan Designation

 Zoning and Land Use

 Transportation Network

Plan Elements

 Vision Statement

 Traffic

 Crime, Safety, and Code Enforcement

 Infrastructure

 Environmental Resources/Protection

 Sense of Place

Appendices

 Current Zoning Map

 Current Land Use Map

 Existing Residential Developments Map

 Recommended Land Use Map

 Stormwater Capital Improvements Map

 Community Preference Survey Results

 Growth and Redevelopment Factors Survey Results

 Additional Resources

Introduction

Neighborhoods are the building blocks of a city. Planning at the neighborhood level is fundamentally important to sustain and improve the quality of life a city has to offer. A neighborhood plan is the blueprint that helps a community evolve from where it is today to where its residents and property owners want it to be in the future.

Over the past few years, the Seagate community has seen an increase in requests for rezoning to higher residential densities. In response to this pressure, Seagate residents and planning staff agreed that a neighborhood study was needed. The purpose of the study, the Seagate Neighborhood Plan, is to identify specific long-term goals, aimed at improving the quality of life in the area, with strategies to achieve these goals. This plan enabled residents and property owners to be more active in charting their own course for the future of the community, thereby proactively preventing neighborhood decline, protecting property values, and building a sense of place.

The Wilmington Future Land Use Plan 2004-2025 (FLUP) identifies 13 distinct neighborhood areas. The Greenville Avenue/Seagate area is identified in the FLUP as a “threatened area.” Threatened areas are defined as those experiencing increased crime, decreased owner-occupancy, decreased property values, escalating code violations, and boarded-up houses. Good planning practice dictates that efforts should be made to assist in revitalizing less stable neighborhoods where there is demonstrated interest on the part of residents and property owners. To help achieve these goals, the FLUP calls for the development of neighborhood plans for each area as a supplement to the strategies in the FLUP. Small area plans are critical to effectively plan for transition since more in-depth analysis is needed to determine its impacts. The Future Land Use Plan designations are described in detail in the “Existing Conditions” section of this plan.

This plan provides specific recommendations and strategies intended to take precedence over the more general guidelines of the Future Land Use Plan. This document is adopted as an amendment to the Future Land Use Plan.

Vision Statement

Through the community input process, a vision statement was developed. This vision statement served as a guide throughout the plan development process and will continue to serve as an inspiration for the future of the community.

“Seagate is a cohesive, safe, environmentally sound, well-designed neighborhood that meets the daily needs of residents by promoting the history of the community, ensuring that development is compatible with neighborhood scale and character, and nurturing an environment that promotes community interaction and neighborhood pride.”

Boundaries

The study area is generally the triangle between Oleander Drive, Wrightsville Avenue and Bradley Creek. This area coincides with the areas designated on the Future Land Use Plan *Transition Map* and incorporates portions of the Oleander Drive *Tier 2 Redevelopment Area*.

Methodology

Extensive field research was conducted in the study area at the outset of the plan development process. In November 2006, a visual survey of each parcel was conducted to verify land uses and photograph each parcel. These photographs are provided as a separate appendix, available in the Development Services Department, the office of the City Clerk, and in the North Carolina Room at the New Hanover County Library (downtown branch).

Following documentation of the existing conditions in the area, four public input sessions were held in early 2007 at Seagate Baptist Church. These sessions were conducted by Planning Division staff to help determine the boundaries of the Seagate study area, to obtain information on the existing conditions in the area, to obtain feedback on the desired future for the Seagate community, and to present staff recommendations to stakeholders.

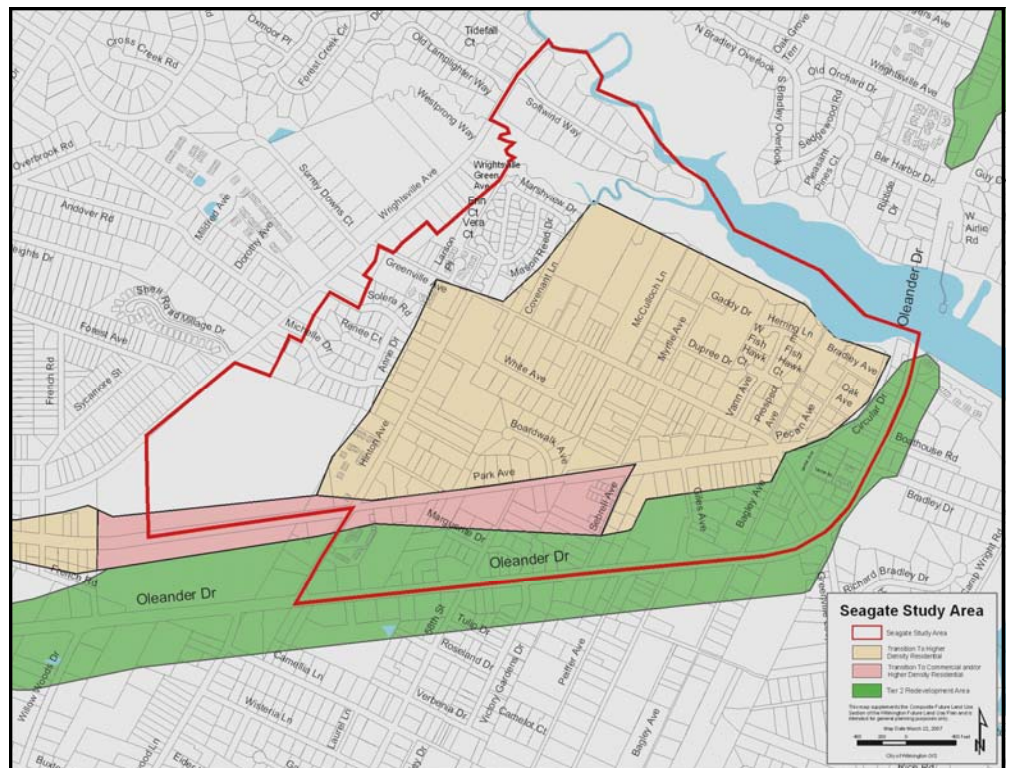

Boundaries of the Seagate study area (red) shown with the Future Land Use Plan *Transition Area* (tan),

Information collected through field research and public input sessions was combined to develop a vision statement for the neighborhood as well as recommended land uses, zoning, and design guidelines for new construction in the Seagate area. All of these recommendations are presented herein.

Seagate History*

The Seagate community has a rich history dating back over a century. The earliest maps on file with the New Hanover County Register of Deeds, dated 1914, show “Sea Gate Park” (Book 2, Page 31) developed on the site of an earlier town called “Greenville,” which was laid out in a rough square divided diagonally by the beach streetcar line (Park Avenue). The Allard-Newber House, circa 1905, is one of the earliest homes existing in



George Rogers Estate where the Seagate Post Office once operated.

Photo taken circa 1995

Photo courtesy of New Hanover County Library

Seagate.

The business and social center of old Seagate was commonly known as “The Hub,” and was located at the intersection of Greenville Avenue, Pecan Avenue, Park Avenue, Lane Street, Greenville Loop Road, and Bagley Avenue. At the center of this hub was the George Rogers home, where the Seagate Post Office operated until 1932. The old Seagate Station for the Tide Water Power Company Rail Road and grocery stores were also located at The Hub.

Although local oral history describes Seagate as a fishing village, Seagate’s history was greatly influenced by the evolution of transportation and growing interest in the beaches. The Tide Water Power Company, which dates back to 1850, operated the streetcars that carried passengers

from downtown Wilmington to Wrightsville Beach. The train ran along Park Avenue, with several stations located along the way, and crossed Bradley Creek to reach Wrightsville Beach. The Wrightsville Turnpike (now Wrightsville Avenue), alternatively known as “the shell road,” also brought passengers through Seagate. The Wrightsville Turnpike had three toll houses, one at 17th and Dock Streets, one in the Winterpark community, and one in Seagate at the Bradley Creek Causeway (demolished).



Train cars on the Bradley Creek trestle circa 1915

Photo courtesy of New Hanover County Library.

Also of note is “The Moorings,” once the home of Confederate Naval officer John Newland Maffitt, located at the terminus of Pecan Avenue on Bradley Creek. The Maffit home burned in the 1920s and was replaced by the rectory for St. Andrews-on-the-Sound Episcopal Church. Today, The Moorings is a private residence. The hallmark architecture of Seagate, however, is the cottage. The landscape of Seagate was historically dominated by these modest single-family cottages and bungalows.

*History compiled from the North Carolina Room at the New Hanover County Library, primarily from the notes of Thomas Newber.

Existing Conditions

For the purposes of this plan, the boundaries of the Seagate study area were defined through the public input process. Historically, Seagate extended from Hawthorne Avenue to the west, southward across Oleander Drive (including the Seagate Cemetery and Bradley Creek Elementary School), and westward to Bradley Creek. Long-time members of the community describe Seagate as being an area much larger than the study area.

Future Land Use Plan Designation

The comprehensive Future Land Use Plan (FLUP), adopted in 2004, identified much of the study area as a *Transitioning Residential Area (Area A on the FLUP Transition Map)*. This designation calls for the consideration of rezoning to allow for higher-density residential uses such as duplexes, triplexes, quadraplexes, and low-density multi-family development. The south side of Park Avenue (east of French Road to Sebrell Avenue, Area K on the *Transition Map*) is designated as an area transitioning from single-family residential to commercial or higher-density residential uses. The FLUP identifies acceptable development patterns in this transition area are nonresidential uses, including office and neighborhood retail, as well as duplex, triplex, quadraplex, and low-density multi-family uses.

This area was identified as being in transition due to several factors, including owner-occupancy rates, an increasing number of code violations, existing subdivision and development patterns, and rezoning precedent established at the time of adoption of the FLUP.

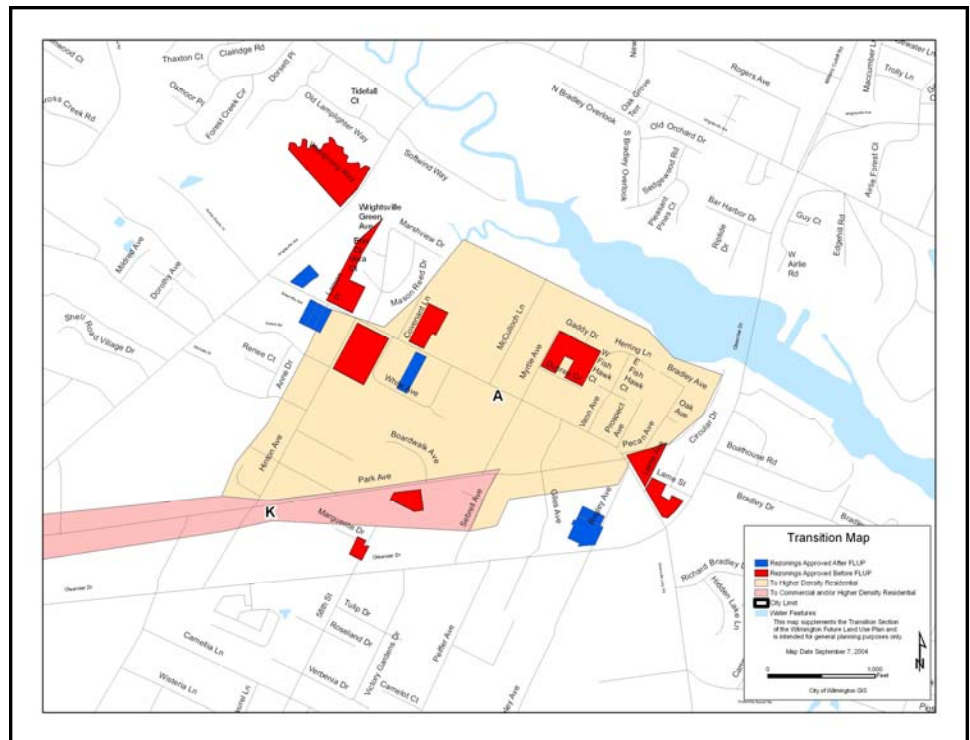

Area rezoning requests approved before (red) the adoption of the Future Land Use Plan and after (blue). The area indicated in yellow represents Transition Area A and the area indicated in tan represents Transition Area K as identified in the Future Land Use Plan.

Between January 2000 and January 2007, a total of 31 public nuisances, 7 minimum housing code violations, and 33 junked vehicles were reported in the area. Stable neighborhoods have much lower incidences of these type violations; however, this high number of reported violations may also indicate an increased interest on the part of residents. According to the 2000 Census, city-wide, 53% of dwelling units are renter-occupied. A total of 66% of the units located in the identified transition area are owned by absentee landowners. This indicates a concentration of rental units and therefore a higher degree of transience than would be expected with a higher number of owner-occupied structures. This owner-occupancy rate is significantly lower than other established neighborhoods. Landfall has an owner-occupancy rate of 94%, Forest Hills, 82%, and Sunset Park, 71%.

Perhaps the most telling sign of a transitioning area is the development and zoning precedent established in the area. At least five higher-density developments were developed prior to the adoption of the Future Land Use Plan as illustrated on the map on page 5. These new development projects set the trend for the consideration of future projects in the area. Additionally, there is no consistent parcel pattern in the area. Lots vary widely in both shape and size and transition in residential development patterns is common in areas with such diverse and inconsistent lot layouts. Many of the existing homes are sited on large lots; this makes it easier to develop and/or redevelop these lots with nontraditional site layouts and higher density residential uses.

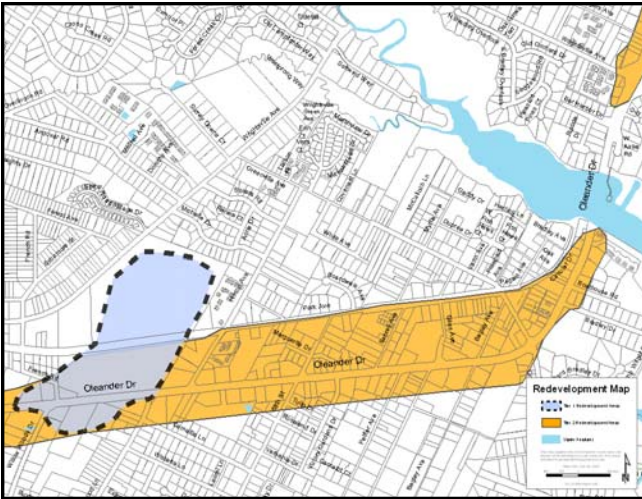

Tier 1 (blue) and Tier 2 (yellow) Redevelopment Areas as identified in the Future Land Use Plan

Since the area was already beginning to transition before the adoption of the FLUP, the area was identified as being suitable for the consideration of single-family, duplex, triplex, quadraplex, and low-density multi-family development.

The Seagate area remains in transition. This neighborhood plan is vital for further defining the appropriate transitions which could be supported in the area. Ideally, this plan, which was developed with a great deal of community input and support, will reduce conflicts in decision making regarding rezoning and development in this area.

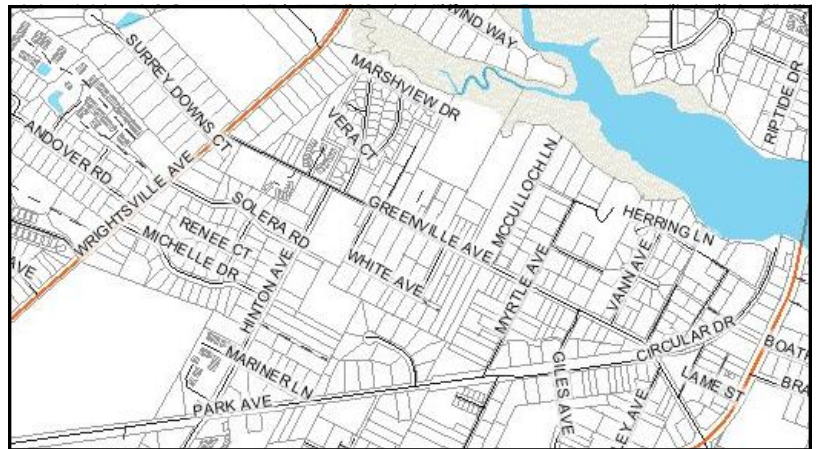

Lot configuration in Seagate (above) is irregular, especially in comparison to a planned development such as Pine Valley (below). While neither pattern is right or wrong, large, irregular lots facilitate development/redevelopment with varied densities and patterns.

The commercial area along Oleander Drive is designated in the Future Land Use Plan as part of a Tier 2 Redevelopment Area. Tier 2 areas are generally characterized by declining or marginal commercial enterprises. In some cases, successful stable businesses are occupying structures or developed sites that do not keep pace with more recent trends in building design and size, do not meet current zoning standards, or are simply unattractive. These properties tend to have little landscaping and few pedestrian amenities. Problems with site functionality and access are also common. Tier 2 areas are targeted for upgrades on an opportunistic basis when the uses change. The redevelopment of targeted areas by expanding, renovating, or entirely replacing these commercial uses will increase the tax base and improve the quality of the built environment.

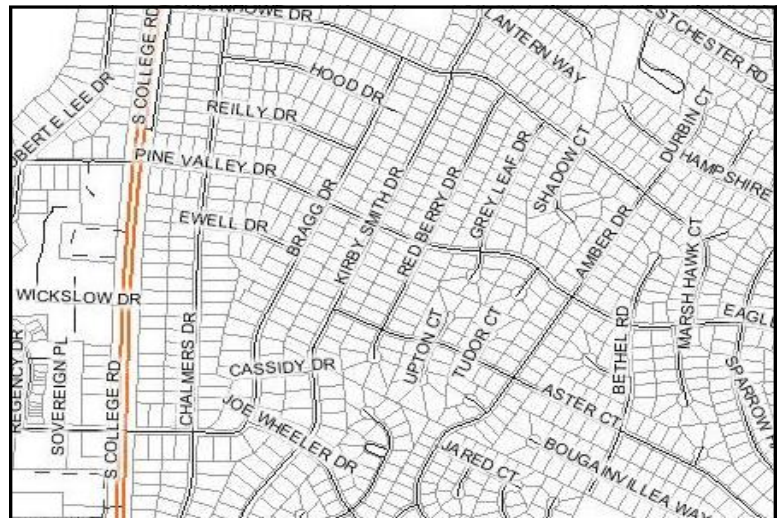

Zoning and Land Use

Most of the Seagate study area was developed under New Hanover County regulations and was part of the 1998 annexation area. Sound's Edge at Bradley Creek, however, was part of the 1995 annexation area. At the time of annexation, the existing residential area was predominantly zoned R-15, with pockets of R-10, under New Hanover County regulations and this designation was carried over upon annexation.



Many older homes in the study area are sited close to the road, particularly along Greenville Avenue.

Current zoning in the study area is predominantly R-15 (residential), with parcels zoned MF-L (Multi-Family Low Density), R-10, and R-5 (residential) scattered throughout. Along Oleander Drive, property is predominantly zoned CB (Community Business) and O&I-1 (Office and Institutional). There are many nonconforming uses in the residential and commercial areas. A copy of the current zoning map is attached (Appendix A).

Residential uses in the area include single-family homes, duplexes and multi-family housing, and mobile homes. The configuration of lots in this area is irregular and it is common for large lots to contain more than

one residence, which does not conform to current regulations. The earliest homes in Seagate are modest, single-story, wood-frame twentieth-century cottages with simple architectural details. Many of these cottages are occupied. Some are well-kept and have been restored while a few others sit vacant and/or are in various states of disrepair. These traditional homes were often sited very close to the street, especially along Greenville Avenue. This pattern of limited setbacks contributes to the neighborhood character. Although there are several historic homes in the area, a number of single-family subdivisions have been developed more recently, including Bradley Park (1970), Wrightsville Green (1987), Sound's Edge at Bradley Creek (1993), Osprey Point (2001), and Preservation Park (2005). There are also several manufactured homes in the area, many of which are located on lots with other single-family residences.

Breakdown of Parcels in Study Area

Residential parcels	400
Commercial Parcels	195
Total Parcels	595
Nonconforming parcels*	43

*These lots contain more than one primary residential structure

Residential Units	
Single-family	372
Duplex	103
Multi-family	49
Manufactured homes	26
Total Residential Units	550

There are several duplex developments in the study area, most of which were constructed prior to the adoption of the Future Land Use Plan in 2004. These developments include Seagate Village (constructed between 1960 and the early 1970s), duplexes at 242 Greenville Avenue (constructed between 1970 and 1995), Park Walk (1985), the duplexes at the intersection of Park and Hinton Avenues (1995), Larson Place (2002), and Hinton Oaks (2003). The Shoreline at Seagate development was constructed in 2005 after the adoption of the FLUP. Property at 239 Greenville Avenue was rezoned in 2006 for the development of two quadraplexes; development plans for this project are currently under review by the city’s Development Services Department. A larger version of the map below is attached as Appendix C.

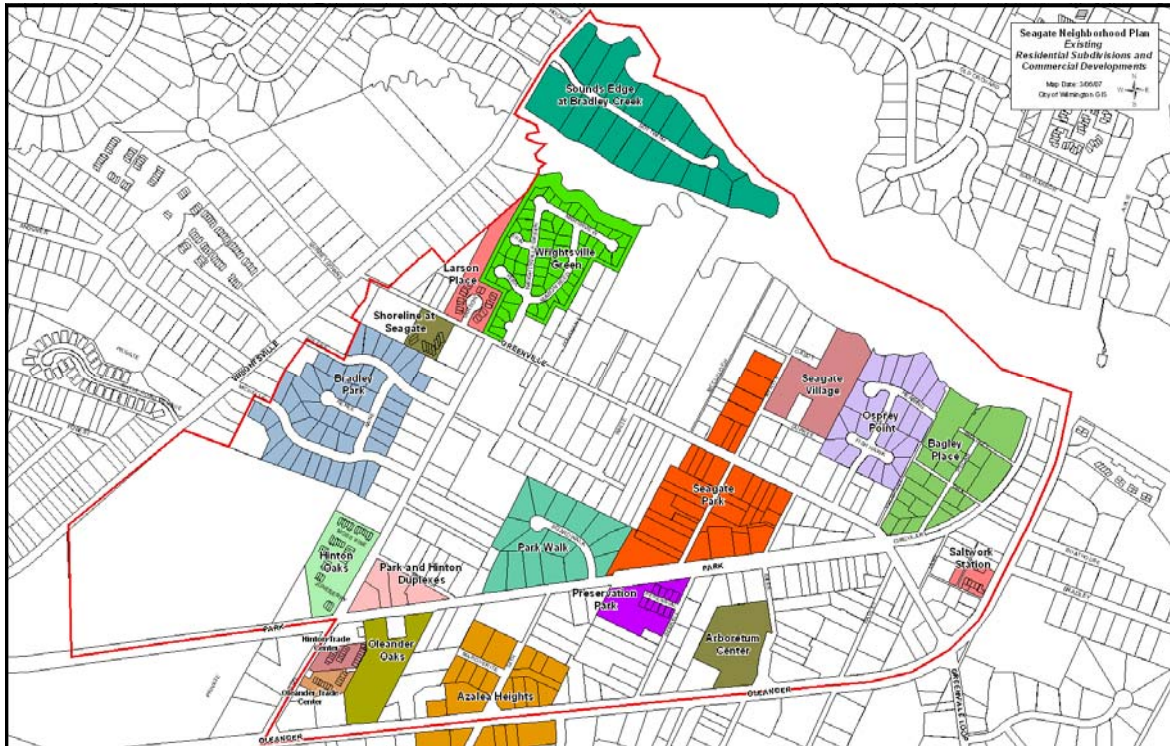

Existing residential developments within the study area.

Commercial development in the study area is largely confined to the area between Oleander Drive and Park Avenue, with some limited commercial uses around the intersection of Wrightsville* and Greenville Avenues. While there are some limited “daily need” types of uses such as restaurants and convenience-type food markets in the vicinity, the commercial uses predominating Oleander Drive are primarily businesses with a regional draw that do not necessarily serve to meet the daily needs of area residents. These regional uses include mobile home dealers, furniture stores, automobile repair shops, and other high-intensity commercial uses.

**Property fronting Wrightsville Avenue is part of the Wrightsville Avenue Corridor Overlay and subject to the regulations of the overlay district and was therefore not included as part of the Seagate study.

Transportation Network

The roads that serve as the boundaries of the study area are Wrightsville Avenue and Oleander Drive, both of which are North Carolina Department of Transportation (NCDOT)-maintained roadways. The primary local roads through the study area are Greenville, Hinton, and Park Avenues. These roads were evaluated in the city's 2006 Pavement Condition Survey and pavement repairs for this part of the city are scheduled for the 2009-2010 fiscal year. The survey results are as follows:

Park Avenue from Greenville Avenue to Hinton Avenue received a rating of poor, citing major edge failure, low and failing utility cuts, severe "alligator distress" due to underlying base failure, bumps and sags, and transverse and longitudinal cracking.

Greenville Avenue from Oleander Drive to Wrightsville Avenue received a rating of fair to very good, citing major edge failure in isolated areas, low and failing utility cuts, moderate alligator distress due to underlying base failure, bumps and sags, and transverse and longitudinal cracking.

Hinton Avenue from Oleander Drive to Greenville Avenue received a rating of fair to very good. The survey recommends maintenance activities ranging from general preventative maintenance to mill resurfacing. Also considered are full-depth repair and an overlay with extra binder installed under the surface-course due to the heavy traffic load and existing pavement distress.

There are very few sidewalks existing in the area. Due to limited right-of-way widths and shallow building setbacks, there is insufficient room for sidewalks along Greenville Avenue. Sidewalks could potentially be accommodated along portions of Hinton, Park, and Bagley Avenues.

The River to Sea Bikeway (Route 1) runs through the study area, extending down Park Avenue, Greenville Avenue, and crossing Bradley Creek along Oleander Drive. There are striped bike lanes along portions of Park Avenue west of Hinton Avenue and sufficient right-of-way exists along Park Avenue along the former trolley path to accommodate a bike path or on-road bike lanes.

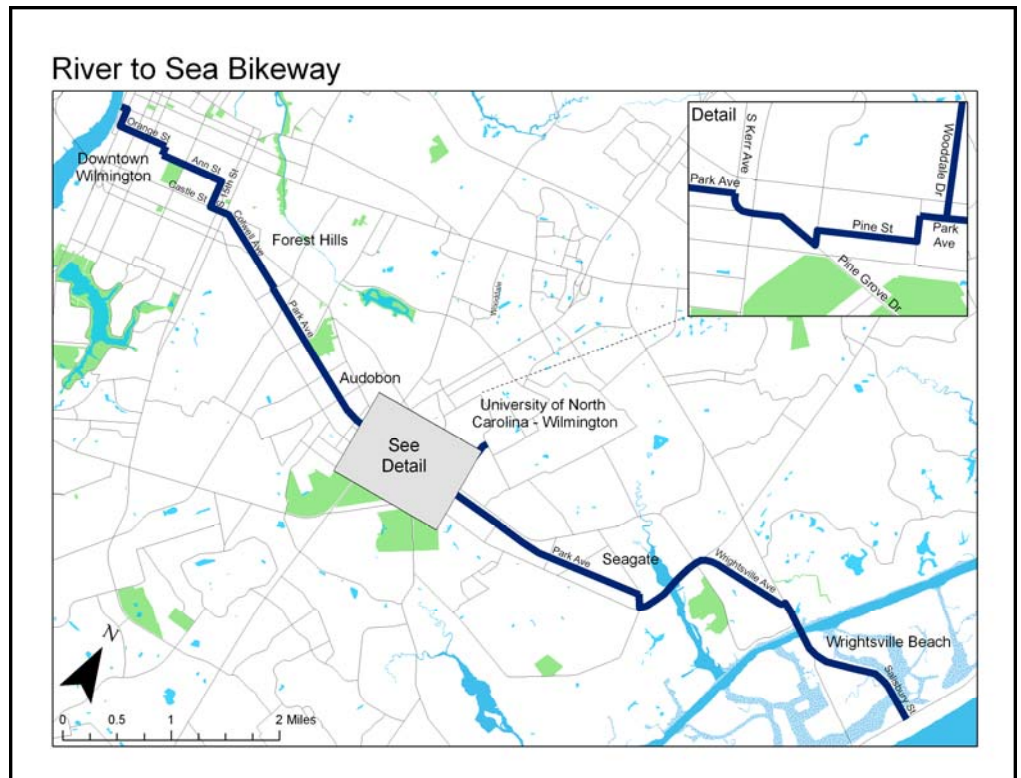

Plan Elements

This is the community's plan. Every element of the plan was developed based on input from residents and property owners. While there has not been total agreement on every issue, "Seagaters" have generally developed consensus on what the future of their community should be.

The action steps presented to implement the plan will require the ongoing effort and vigilance of the Seagate community.

The key to the success of the Seagate Neighborhood Plan is a strong, organized, unified neighborhood association. Every effort should be made by the neighborhood to create and maintain an organization, representative of property owners and residents alike, that presents a unified voice for the community.



Stakeholders work with city staff members during the planning process

Vision Statement

A successful community requires a shared vision of what it can be. Based on the feedback received throughout the planning process, a vision statement and five themes were developed. The vision statement that has guided the development of the plan is: **“Seagate is a cohesive, safe, environmentally sound, well-designed neighborhood that meets the daily needs of residents by promoting the history of the community, ensuring that development is compatible with neighborhood scale and character, and nurturing an environment that promotes community interaction and neighborhood pride.”**

Plan Themes

The major elements of the plan were developed through the public input process. At the first meeting, participants were asked to rank issues in order of importance. They were also asked to identify the strengths, problems, opportunities, and threats in the area. This feedback was used to identify major elements or themes that formed the plan. At the second meeting, the five elements were presented and participants were asked to refine these themes and to begin brainstorming ideas and solutions to address these concerns. The themes are interrelated and the supporting objectives listed under one particular theme may serve to meet the goals of multiple themes. These themes are:

- Traffic
- Crime, Safety, and Code Enforcement
- Infrastructure
- Environmental Resources/Protection
- Sense of Place

Traffic

Residents consistently identified traffic as a concern. Traffic issues include speed limits, number of collisions, pedestrian safety and lack of sidewalks, transit options, and traffic signal locations. Currently, local roads are operating under capacity. Greenville, Hinton, and Park Avenues operate at level of service “A.”

A Neighborhood Traffic Study was conducted concurrently with the neighborhood planning process. Vehicle speeds were studied as part of the Neighborhood Traffic Study and it was found that along most roads in the study area, vehicles were traveling above the posted speed limit of 35 miles per hour. As a result of the study, City Council approved lowering speed limits in the study area to 25 miles per hour at their April 3, 2007 meeting. The Neighborhood Traffic Study addresses additional specific short-term and long-term solutions to traffic safety issues. A copy of the Neighborhood Traffic Study is available under separate cover in the city’s Development Services Department.

Below are the action steps recommended to address traffic concerns.

Goal: To promote safer, better-maintained travel routes that accommodate vehicular and non-vehicular modes of transportation.

Objective – Reduce Vehicle Trips – Providing safe alternatives to vehicle travel promotes community involvement and reduces environmental impacts.

Action Steps:

- I.1 Incorporate sidewalks and bike paths where possible to minimize vehicle trips.
- I.2 Support developments that are designed to accommodate convenient access to public transit (there is currently a WAVE Transit bus stop on Oleander at the arboretum).
- I.3 Support and promote interconnectivity among developments.
- I.4 Support and promote the results of the city’s Neighborhood Traffic Study.
- I.5 Install sidewalks and bike paths where sufficient right-of-way exists.
- I.6 Design new developments to share driveways where possible to reduce the number of curb cuts.

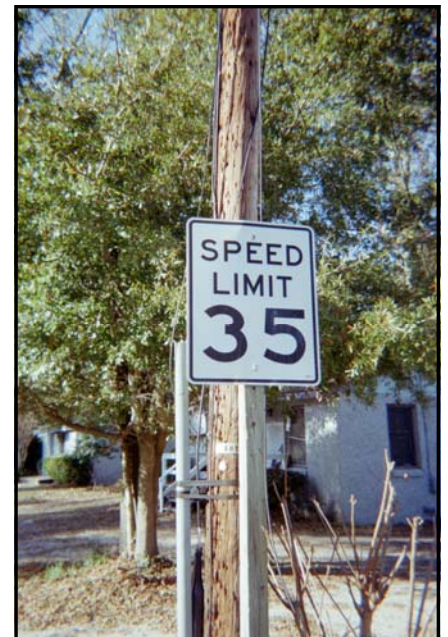

Crime, Safety, and Code Enforcement

Seagate was identified as a Transition Area in the Future Land Use Plan in part because of crime, safety, and maintenance issues. Stable neighborhoods have much lower incidences of public nuisance reports, minimum housing code violations, and junked vehicle reports than the Seagate area. Seagate also has a large concentration of rental units and therefore a higher degree of transience than would be expected with a greater number of owner-occupied structures. The more property owners are engaged, the greater reduction in crime, safety, and code enforcement problems the neighborhood will see.

During the input process, the Seagate identified specific issues including theft, vandalism, speeding and traffic violations, noise and a general need to “clean up” the neighborhood. Residents are concerned with yard trash and the decline of some properties in the area. An often-expressed concern was the lack of upkeep of rental properties and absentee landlord accountability.

Goal: To create a safer and better-maintained neighborhood that promotes a strong sense of community in the Seagate area.

Objective 1 – City Code Enforcement and Police Action – Promote and utilize city services to reduce crime, improve property maintenance, and educate citizens and business owners in the Seagate community on these issues.

Action Steps:

- I.1 Aggressively report code violations, public nuisances, and minimum housing code violations to code enforcement.
- I.2 Support increased police presence in the area to enforce speed limits, set up checkpoint stations, and monitor noise and parking violations.
- I.3 Utilize a neighborhood association to develop a strong working relationship with city code enforcement and police officers.

Taking simple steps, like bringing trash carts back from the curb immediate after pick-up, will help eliminate debris in the area.



Objective 2 – Community Involvement – Involve residents, property owners, and business owners in developing an environment that promotes community safety and neighborhood pride. Engaging absentee landlords and negligent property owners is essential to cleaning up the neighborhood.

Action Steps:

- 2.1 Report all crime activity and code violations when they occur.
- 2.2 Distribute a list of city resources and services to all property owners and residents.
- 2.3 Follow up with the assigned code enforcement or police officer for questions regarding resolutions to reported problems.
- 2.4 Establish a neighborhood association to notify absentee property owners of illegal activities and maintenance problems occurring on their property.
- 2.5 Establish a neighborhood association to encourage and organize the involvement of residents in neighborhood improvement efforts modeled after programs such as neighborhood watch or “eyes on the street” programs and “adopt-a-street” litter control.

Infrastructure

An aging sewer system, the poor condition of roads, lack of sidewalks, and lack of park space were listed as concerns regarding infrastructure; however, stormwater and drainage dominated the list. Lack of park space, sewer issues, and stormwater drainage problems are city-wide concerns and not unique to Seagate.

In 2006, Wilmington voters approved a parks bond to acquire and maintain park space. Bond funds have been allocated for the annexation areas, of which Seagate is part.

The city has adopted a Stormwater Master Plan that is being implemented through the capital improvements program. A drainage project along Dupree Drive is underway. Other identified drainage projects include Michelle Drive/Bradley Creek Southern Branch (proposed for construction in 2007-2008) and Greenville/White Avenue (proposed for construction in 2009-2010). The Wrightsville Avenue culvert is scheduled to be replaced and is in the planning and design stage and the Seagate drainage project at Greenville Loop Road and Oleander Drive was completed in 2006. The Stormwater Capital Improvements Implementation map is included as Appendix E. Representatives from the city's Stormwater Services Division participated in the community meetings and conducted a survey on the community preferences related to stormwater management. The results of this survey are available under separate cover within the city's Stormwater Services Division in the Public Services Department.

Goal: To maintain adequate infrastructure to support the needs of the area while proactively addressing future needs and resources.

Objective 1 – Stormwater and Drainage – support the ongoing efforts to improve stormwater management in the area.

Action Steps:

- I.1 Support the efforts of the city throughout the implementation of the stormwater capital improvements project.
- I.2 Limit impervious surface coverage and utilize pervious paving materials and other best management practices (BMPs).
- I.3 Provide green/open space, including expanded buffers and preservation of existing natural areas.
- I.4 Maximize the use of buffers and natural wetland functions for stormwater quality management.

Objective 2 – Park Space – Dedicate land for public park space.

Action Steps:

- 2.1 Encourage the dedication of vacant land (currently privately owned) located at the northwest

corner of the intersection of Greenville and Park Avenues for park space.

- 2.2 Encourage dedication of open/park space as part of new private developments in excess of the city's minimum requirements.
- 2.3 Pursue local historic landmark designation for the Wilmington-Wrightsville Beach trolley path.
- 2.4 Encourage the dedication of land along Bradley Creek (that is currently private) for public access to the water, including passive and active recreation areas.

Objective 3 – Sidewalks and Bikepaths – Support installation of pedestrian and non-motorized transportation amenities throughout the area.

Action Steps:

- 3.1 Install sidewalks and bikepaths where sufficient right-of-way exists.
- 3.2 Include sufficient pedestrian circulation to facilitate community interaction.
- 3.3 Extend the existing bikepath along Park Avenue, including the Bradley Creek crossing..
- 3.4 Utilize and promote existing resources such as the River to Sea Bikeway.



Environmental Resources/Protection

Environmental issues ranked high on the list of stakeholder concerns. Of particular interest is the protection of Bradley Creek and the Bradley Creek watershed. In addition to water quality, other specific issues identified through the public input process include litter and trash on the streets, preservation of existing green space, lack of green space, the amount of impervious surface coverage in the area, and the effects of the recent sewer leaks. Protection of the environment is closely tied to infrastructure, especially stormwater management.

The study area is in the Bradley Creek watershed and contains several wetland resources that are subject to the city's Conservation Overlay District Requirements. Bradley Creek was recently rated as only "partially supporting of its intended use" due to degraded water quality. Any development in the study area, particularly along Bradley Creek, should incorporate site-sensitive designs that consider water quality impacts. The remaining wetland resources should be preserved to the greatest extent possible for their habitat and water quality value as well as for passive recreation.

The Wilmington-New Hanover County Land Classification Map classifies Seagate as part of the Watershed Resource Protection area. According to the CAMA Plan, impervious surface coverage should be limited to 25% in Watershed Resource Protection areas unless projects are "exceptionally designed" (as defined by Article 10 of the city's Land Development Code).

Goal: To protect and preserve existing natural resources in Seagate, including maintaining and improving water quality, dedicating public open space, and reducing human impacts.

Objective I – Keep Seagate Clean and Green – Reduce the amount of litter and garbage that is improperly disposed of and improve the landscape.

Action Steps:

- I.1 Report illegal dumping. Utilize a neighborhood-watch or "eyes on the street" format to monitor dumping, particularly on Circular Drive.
- I.2 Utilize a neighborhood association to monitor improper storage/disposal of residential refuse and report violations.
- I.3 Remove trash carts from rights-of-way as soon as possible on collection days.
- I.4 Utilize existing services offered by the city to pick up bulky items, extra refuse that does not fit in trash carts, curbside recycling, and yard waste.
- I.5 Report violations of the city's solid waste code.
- I.6 Compost yard waste and mulch leaves and grass clippings. Do not mix non-organic items (plastic, cans, building materials, etcetera) with yard waste. Keep leaves and yard waste from washing into ditches and storm drains.

- 1.7 Develop a community-based “Hands-on Seagate” program to involve residents and property owners in a quarterly clean-up effort for the area.
- 1.8 Plant trees for shade and to provide visual buffers.

Objective 2 – Protect Bradley Creek – Minimize water quality degradation and protect remaining wetland resources.

Action Steps:

- 2.1 Utilize site-sensitive design principles, including minimizing impervious surface coverage, maximizing the use of riparian buffers, using natural wetlands functions for stormwater management, maximizing tree retention, green roof construction, low-impact design (LID) techniques, and transportation alternatives.
- 2.2 Continue to monitor and improve the water quality of Bradley Creek.
- 2.3 Restore and/or create new vegetative buffers along Bradley Creek where parcels are already developed or as they are redeveloped.
- 2.4 Support higher residential densities, in accordance with the plan’s *Recommended Land Uses* map, and cluster subdivisions (utilizing “exceptionally designed” project standards) in exchange for increased preservation of natural areas.

- 2.5 Employ xeriscaping landscaping practices which minimize the need for water, fertilizer, pesticides, and herbicides.
- 2.6 Employ water conservation measures for household and business water consumption.
- 2.7 Always remove pet waste, even in private yards, and properly dispose of it to prevent it from washing into ditches and storm drains.

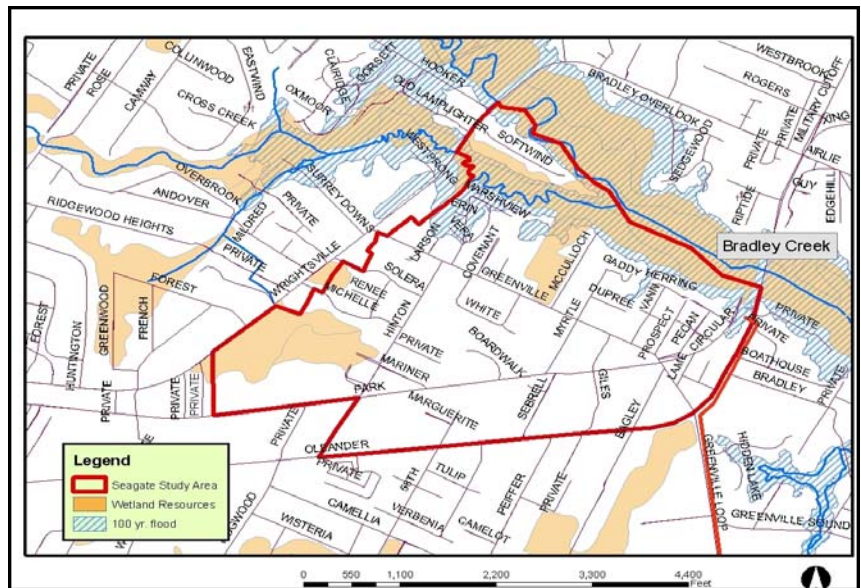

- 2.8 Work with the New Hanover County Soil and Water Conservation District to identify opportunities for voluntary water quality best management practices for residences and businesses, including rain gardens, swales, rain barrels, and stream bank restoration.

Sense of Place

“Sense of place” is the most far-reaching element in the plan. It is also the most controversial issue and the one on which opinions varied the most. Specific issues identified through the community input process included the desire to build a sense of community, lack of owner-occupancy and number of rental units, determining appropriate density, building and site design, preservation, and recognition of history.

The population of Wilmington, like the rest of the country, is growing. While population grows, the amount of land we have remains constant. Given the need for housing generated by this population growth, the tendency to sprawl puts a significant strain on our economy and our environment. We must proceed carefully and make deliberate choices about the use of our finite amount of land.* The need for all housing types is evident throughout the city. The Seagate area is a transitioning area and it is unrealistic to expect that change will not occur. It is reasonable, however, to expect these changes to appropriately reflect Seagate’s character, history, and sense of place. Given the rising cost of land and scarcity of vacant land, the pressure to infill and redevelop the Seagate area is not likely to diminish. It is crucial that redevelopment occur in a manner that is suitable for the community while still meeting the market demands of the region.

Higher density is not a new development pattern. This pattern is evident downtown, in historic neighborhoods such as Carolina Place, Chestnut Heights, and even in Seagate. In fact, nationwide, 40 percent of existing housing units are attached or multi-family (US Census Bureau, 2000). Allowing zoning options can increase choices available to homebuyers. As demographics shift, the need for smaller homes and smaller lots increases city-wide. Provisions for sufficient open spaces, nearby consumer services and mix of uses, sufficient infrastructure, and convenient transit service must be taken into account when considering density increases. Moderate densities can be achieved through an interesting combination of housing types and designs, including cottages, bungalows, duplexes, and townhouses that enhances a community. The key to creating density that is appealing, high-quality, and compatible with the character of the neighborhood is to plan and design it well. The way density is perceived has less to do with the actual number of units per acre than how well the built environment is designed. This section contains examples of preferred development patterns that, if followed, will result in new developments that are compatible with the character of Seagate, regardless of density.

To be workable, any plan needs to incorporate change and development as well as preservation. Development will continue to occur; successful communities are not static. Effective involvement requires persistence, flexibility, vision, and a sustained presence from all residents and property owners.



Havasu City, AZ 2.0 units / acre



Boulder, CO 12.5 units / acre

These two photos illustrate that, no matter the geographic location, the character of the built environment is often more important than the actual densities of developments. The design of dwelling units, the provision of open space, tree coverage, and the location and design of parking may contribute to the character of an area in greater measure.

Photos from *Visualizing Density*.

* Campoli, Julie and Alex S, MacLean. *Visualizing Density*. Lincoln Institute of Land Policy. 2007.

Goal: To maintain the unique character and sense of place within the Seagate community while recognizing that redevelopment and infill are critical to the survival of the community. Ensure that new development is compatible with character of the area.

Objective 1 – History and Preservation –

Promote and protect existing historic resources and tell the Seagate story.

Action Steps:

- 1.1 Identify historically significant buildings and sites, including historic homes, the site of The Hub, the Wilmington-Wrightsville Beach trolley path, and other sites of interest. Develop and implement a signage program to recognize significant buildings and sites.
- 1.2 Pursue the recreation of the Seagate Station as was done in the Audubon neighborhood.



Seagate Station, circa 1918. Photo courtesy of New Hanover County Library.

Objective 2 – Community Involvement – Create an environment that promotes community interaction and neighborhood pride. Engaging absentee landlords and renters/tenants as well as owner-occupants in the community is critical to fostering a sense of neighborhood pride.

Action Steps:

- 2.1 Create and maintain a neighborhood association that solicits the participation of all residents and property owners.
- 2.2 Find examples of other neighborhoods, such as Sunset Park and Audubon, with similar characteristics that have maintained community involvement and pride.
- 2.3 Actively engage tenants and absentee landlords in the community, ensuring that they know about community issues and events.
- 2.4 Develop a periodic neighborhood publication, published and distributed by the community, to keep community members up to date on local events and issues.

Objective 3 – Rezoning and Density – Utilize the zoning map amendment process and the associated public hearing process to insure that new development is consistent with the character and development of the area.

Action Steps:

- 3.1 Support development/redevelopment for property as zoned, or support only conditional district rezoning in accordance with the *Recommended Land Use Map* (Appendix D).
- 3.2 Support development/redevelopment that promotes the vitality and stability of the neighborhood.

- 3.3 Consider neighborhood-scale mixed-use and park space on the large parcel between Park and Wrightsville Avenues (the purple area on the *Recommended Land Uses* map).

Objective 4 – Community Design – Utilize context-sensitive design to insure that new development is consistent and compatible with existing development.

Action Steps:

- 4.1 Encourage new residential development that provides opportunities for community interaction through the use of elements such as sidewalks, architectural features (porches, windows, side- or rear-loading garages, etcetera), and building orientation.
- 4.2 Orient new developments toward and address the primary street. Residential parking lots are discouraged. Do not locate parking, including garages, in the front of buildings or within the front yard setback in any configuration. Design garages to be side- or rear loading. Front facades should not be dominated by garages nor should garages project beyond the front plane of the dwelling unit. Where possible, design units to utilize shared driveways or alleys.
- 4.3 Design new construction to include architectural details that add interest. It is not necessary to replicate existing building styles in order to maintain neighborhood character, although generic, non-descript architecture that does not consider the context of the area is discouraged.
- 4.4 Design new residences to reflect the single-family character of the area. This continuity of character is delivered through the design of individual buildings as well as through the comprehensive design of the entire site. Consider the following elements:

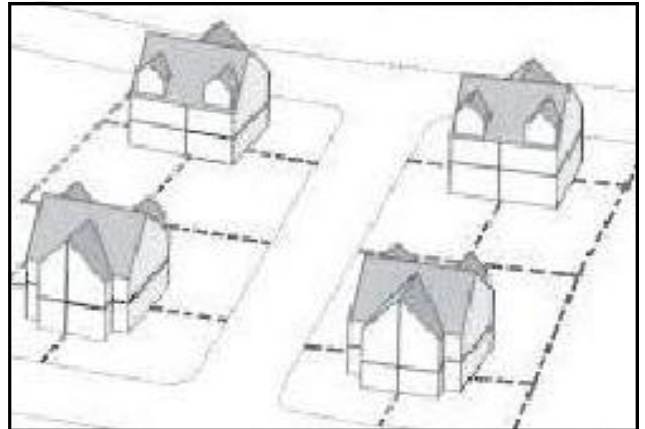

Even quadplexes can be designed to reflect a single family character.

- Setbacks—situate dwelling units on lots with shallow setbacks, as typical in the community, rather than deep setbacks.
- Roofs—design roof pitches and rooflines that are similar to the predominantly occurring roof pitch in the area.
- Building Materials—utilize traditional building materials such as clapboard or materials such as fiber cement board that convey authentic materials instead of vinyl.
- Fenestration—use windows and doors to clearly indicate the front of the dwelling and ensure that there are no blank facades facing streets.
- Orientation—clearly orient new dwellings toward the main road.

- 4.5 Preserve and maintain existing vegetation where possible. Provide landscaping for new construction beyond minimum Land Development Code requirements where possible.
- 4.6 Pursue adoption of a neighborhood overlay district to guide the design of new residential and/or commercial construction.
- 4.7 Pursue adoption of a Seagate Overlay District to codify design regulations for commercial development along Oleander Drive.



Streetyard landscaping beyond minimum requirements is encouraged. Architectural details, such as porches, and sidewalks encourage community interaction.

Encouraged and Discouraged Elements

Setbacks

Encouraged

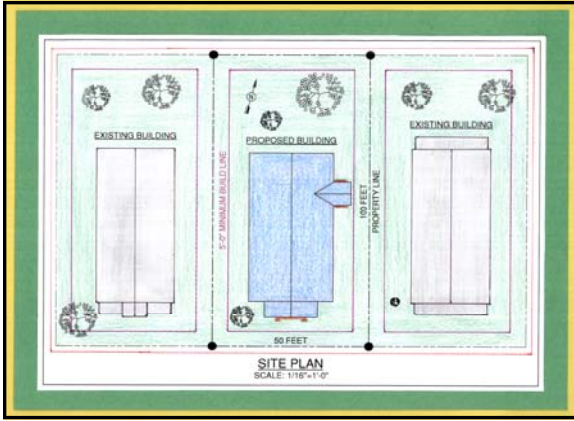

Design new buildings with shallow rather than deep setbacks that are consistent with the predominantly occurring setbacks in the immediate vicinity. Drawing courtesy of Thomas Denton.

Discouraged

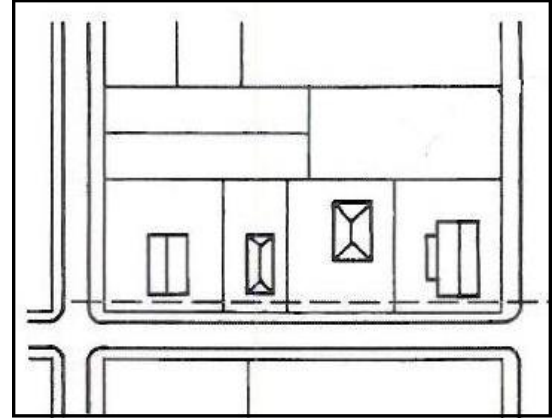

Building setbacks should not be too deep, but should align with the predominantly occurring setbacks in the immediate vicinity.

Roofs

Encouraged

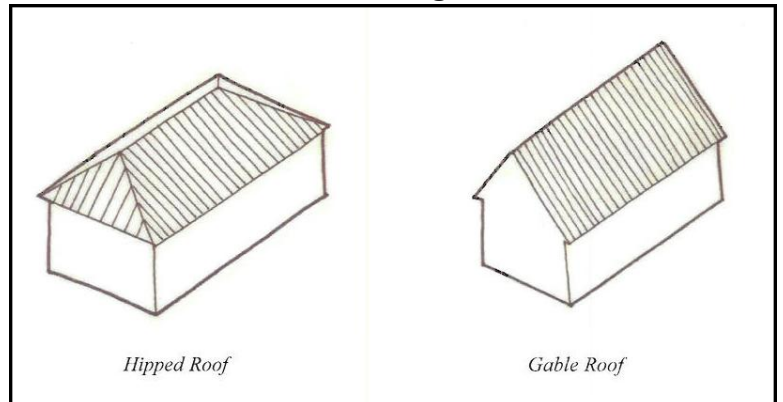

Discouraged

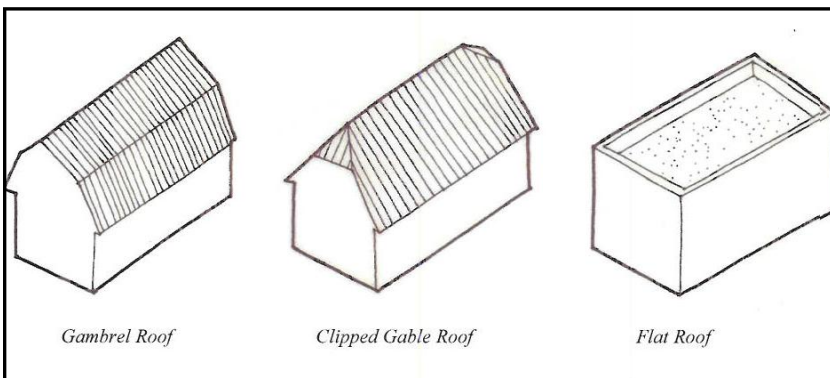

New dwelling units should incorporate rooflines and roof pitches that match the predominantly occurring forms in the area. In Seagate, gable and hipped roofs are the most commonly occurring rooflines.

Parking, Driveways, and Garages

Discouraged



Do not locate parking, driveways, or garages in front of dwelling units.

Discouraged

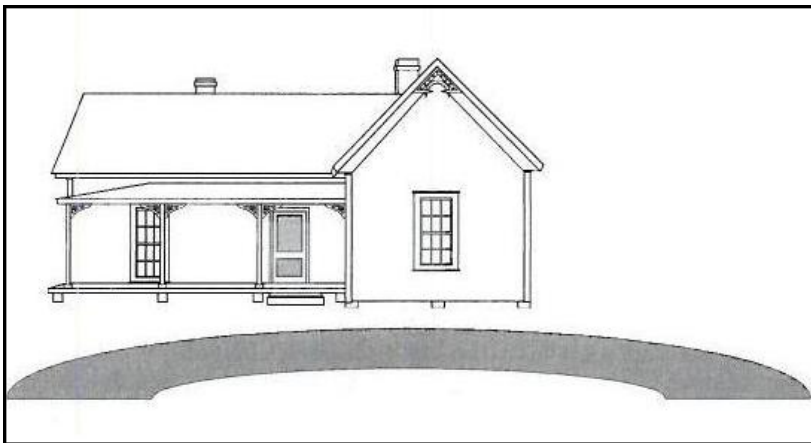

Encouraged

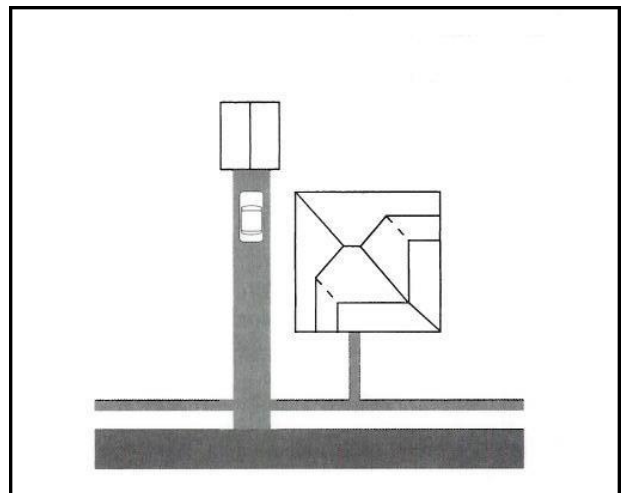
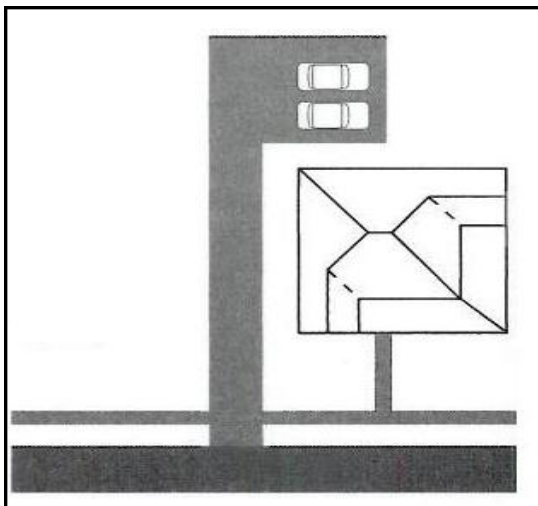

Locate parking and garages to the rear of dwelling units.

Window/Door Openings and Orientation

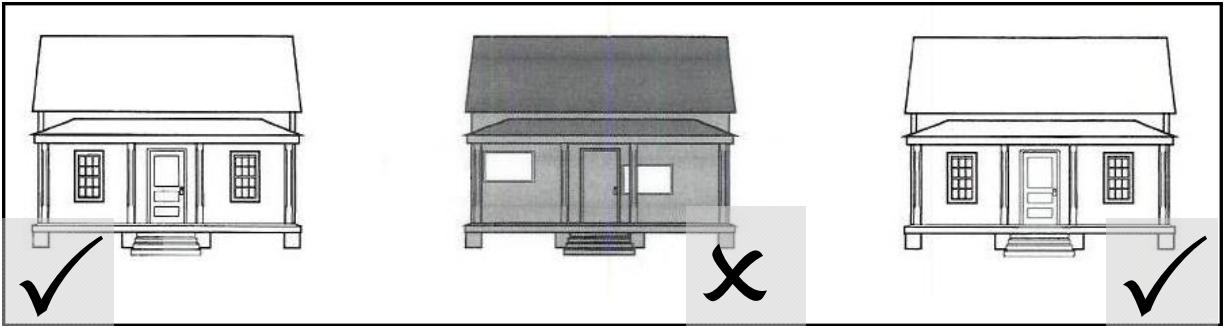

Arrange windows and doors to reflect the character of the traditional houses in the neighborhood.

Discouraged

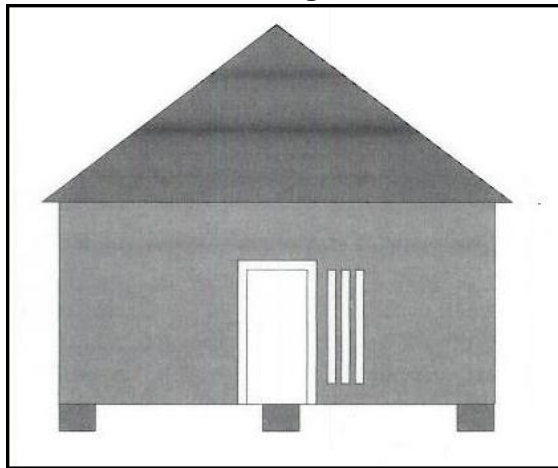

Place windows and doors so that they clearly define the front of a dwelling unit.

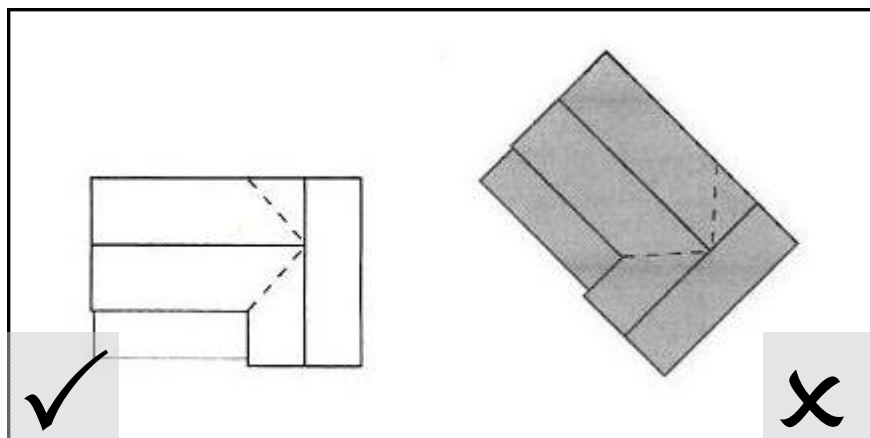

Orient dwellings toward the main road.

Discouraged

These duplexes incorporate several discouraged elements, including front loading garages that project beyond the front plane of the dwelling unit, limited architectural details, and orientation around a cul-de-sac rather than toward the main road.



Discouraged

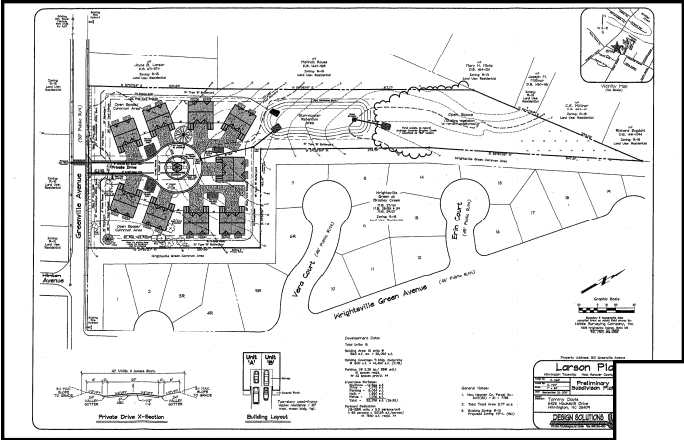

Encouraged

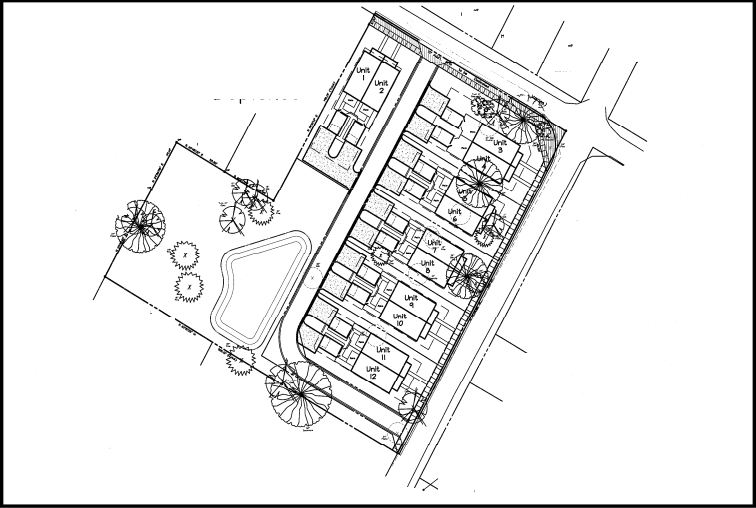

Encouraged



This plan for duplexes incorporates an alley for shared access rather than individual driveways, garages and parking to the rear of the dwelling units, and dwelling units that are oriented toward the main streets.

These duplexes incorporate encouraged elements, include details such as porches to provide architectural interest and single-family character, limited front setbacks, orientation toward the main road and shared driveway to provide parking behind the buildings.

Appendix A – Current Zoning

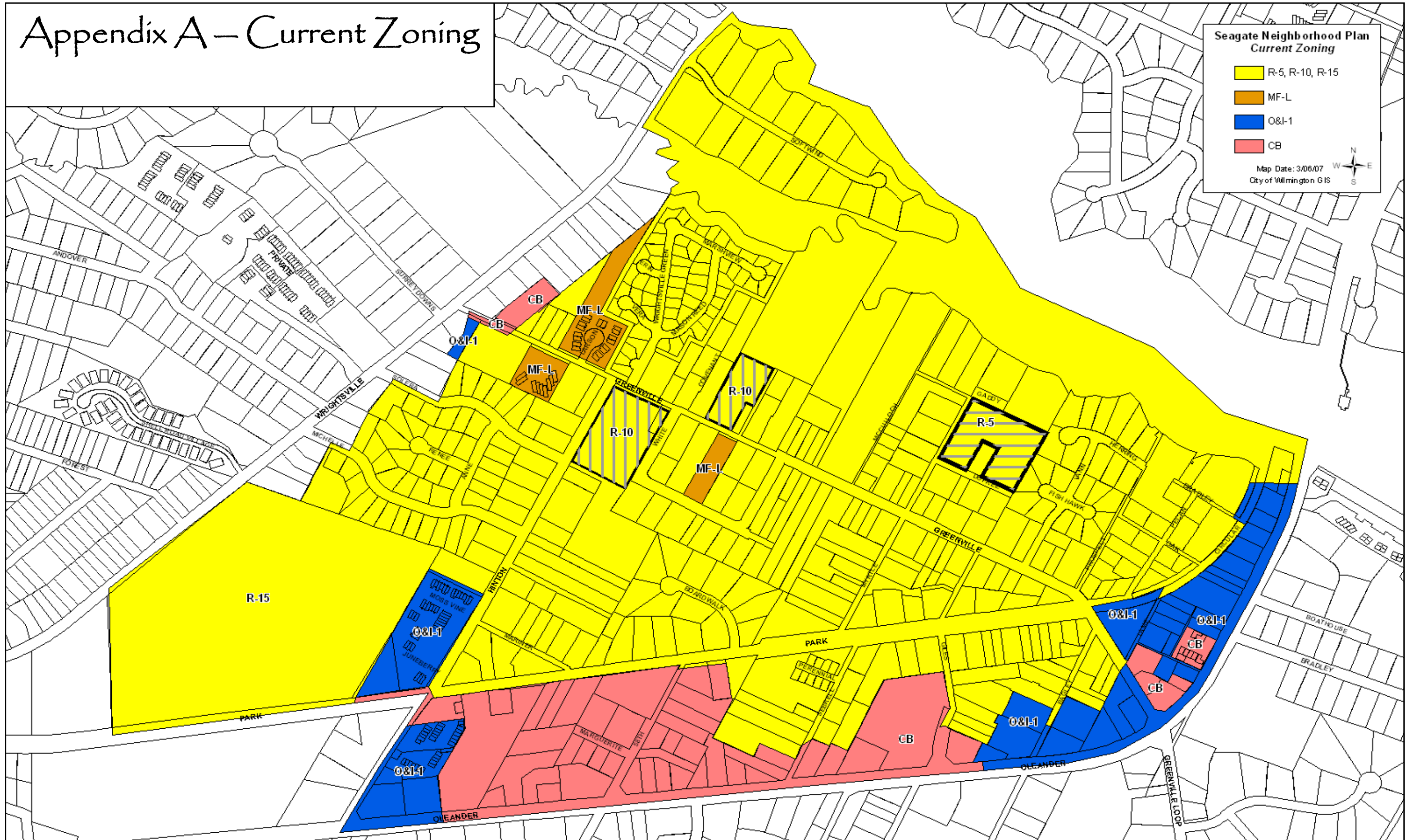

Appendix B – Current Land Use

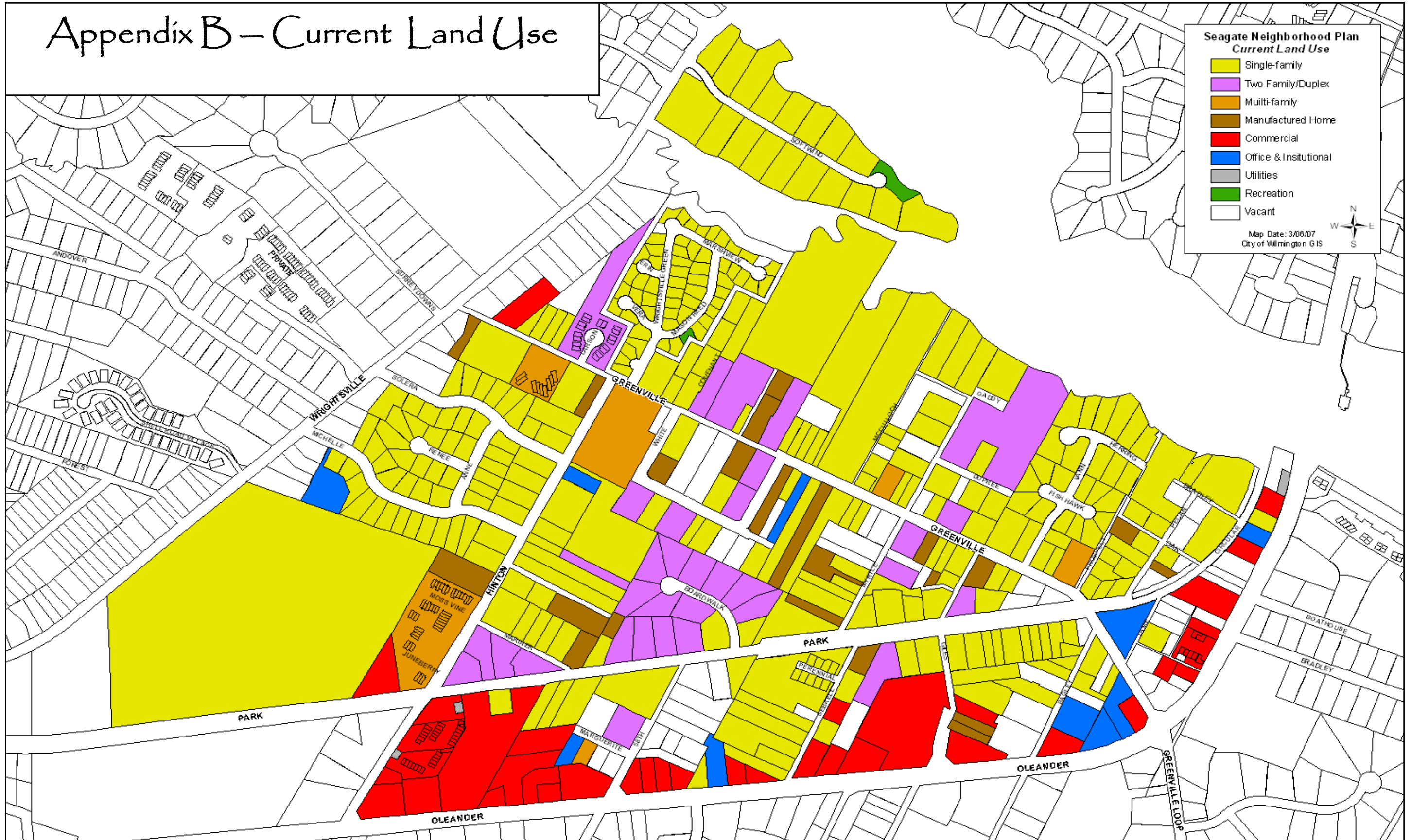

Appendix D – Recommended Land Use

Seagate Neighborhood Plan Recommended Land Use

Map Date: 5/8/07
City of Wilmington GIS

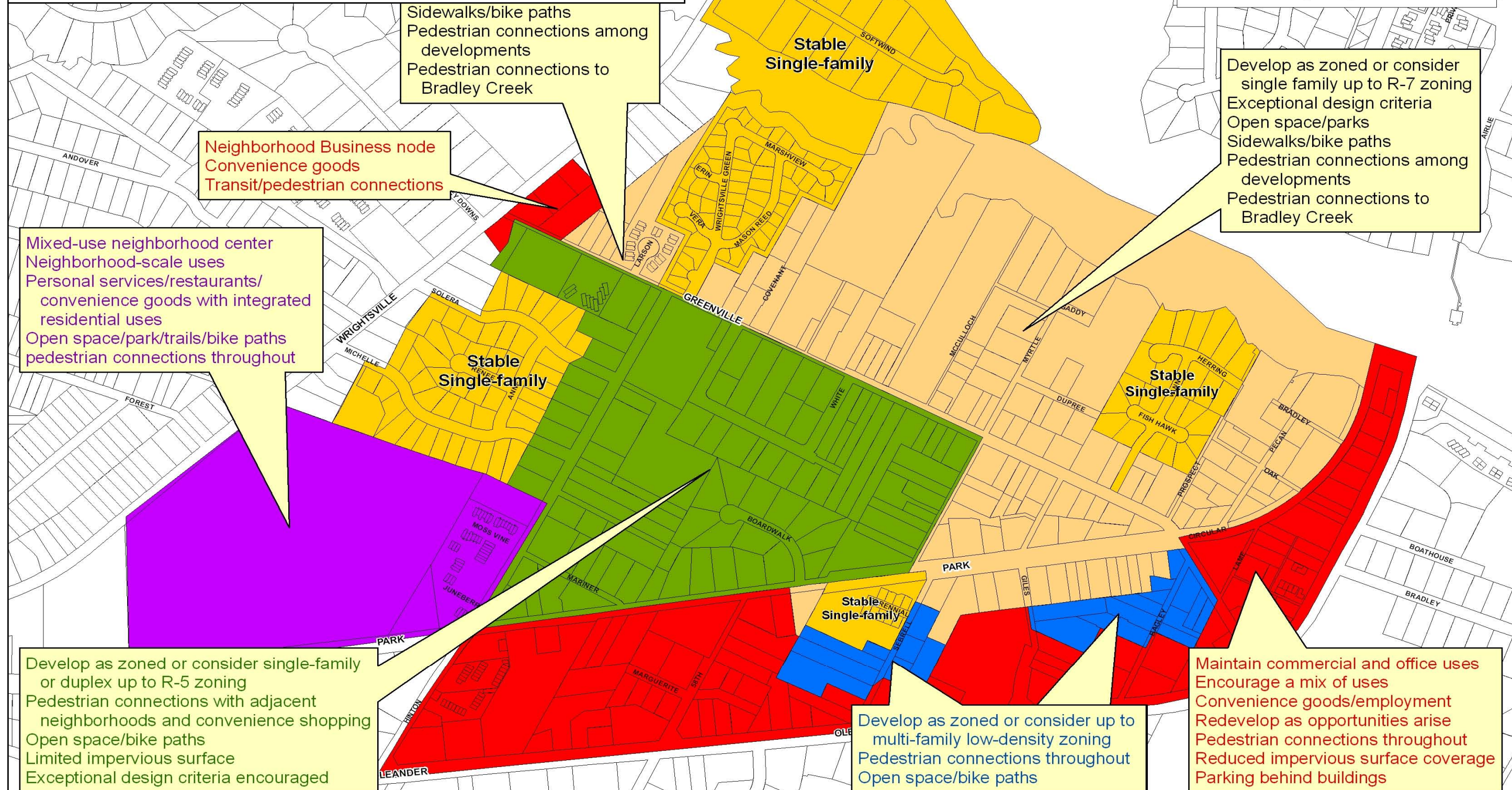

Sidewalks/bike paths
Pedestrian connections among developments
Pedestrian connections to Bradley Creek

Neighborhood Business node
Convenience goods
Transit/pedestrian connections

Mixed-use neighborhood center
Neighborhood-scale uses
Personal services/restaurants/
convenience goods with integrated
residential uses
Open space/park/trails/bike paths
pedestrian connections throughout

Develop as zoned or consider
single family up to R-7 zoning
Exceptional design criteria
Open space/parks
Sidewalks/bike paths
Pedestrian connections among
developments
Pedestrian connections to
Bradley Creek

Develop as zoned or consider single-family
or duplex up to R-5 zoning
Pedestrian connections with adjacent
neighborhoods and convenience shopping
Open space/bike paths
Limited impervious surface
Exceptional design criteria encouraged

Develop as zoned or consider up to
multi-family low-density zoning
Pedestrian connections throughout
Open space/bike paths

Maintain commercial and office uses
Encourage a mix of uses
Convenience goods/employment
Redevelop as opportunities arise
Pedestrian connections throughout
Reduced impervious surface coverage
Parking behind buildings

Appendix E – Stormwater Capital Projects

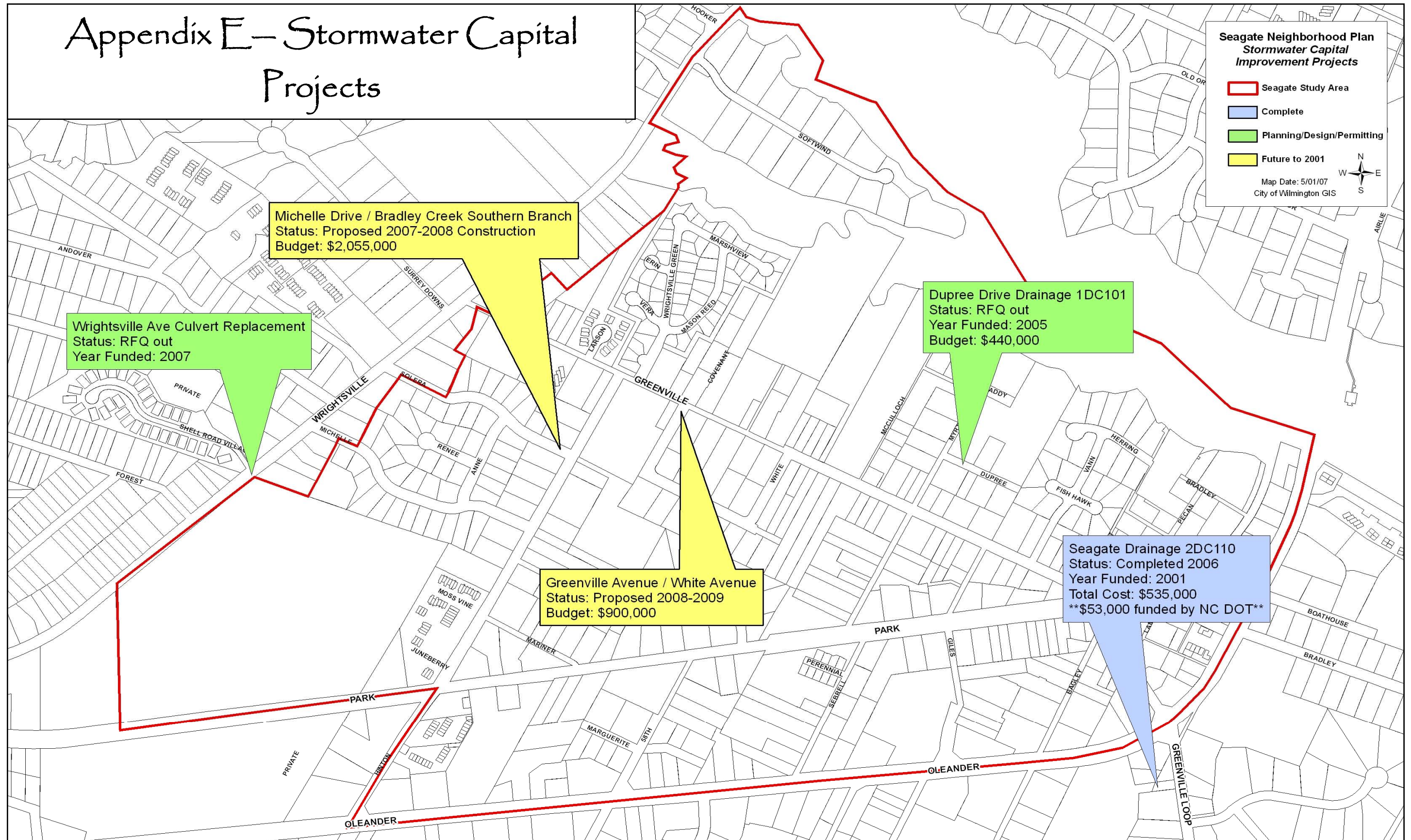

Appendix F—Community Preference Survey - Results

The following is a series of community opinion statements. These statements are provided to help determine specific direction and the statements do not reflect any official City opinion. They are intended to generate input at a more specific level than simply asking what the community likes or does not like. Please circle your opinion from “Strongly Agree” to “Strongly Disagree” for each statement.

When I purchased property in Seagate, a major factor in my decision to purchase is what the neighborhood would be like in 20 years.

42%	29%	15%	8%	6%
Strongly Agree	Agree	Neutral	Disagree	Strongly Disagree

All properties located within the Seagate area should be developed or redeveloped as zoned.***

4%	19%	4%	37%	37%
Strongly Agree	Agree	Neutral	Disagree	Strongly Disagree

Rezoning to allow for mixed-density residential uses is appropriate for the area as long as adjacent properties are properly buffered and roads can handle any additional traffic associated with the change in use.

13%	25%	10%	23%	29%
Strongly Agree	Agree	Neutral	Disagree	Strongly Disagree

The free market should guide development with very little input from government and/or citizens.

0%	10%	10%	19%	62%
Strongly Agree	Agree	Neutral	Disagree	Strongly Disagree

Older, deteriorating residential neighborhoods should be allowed to redevelop to meet modern market demands even if it means shifting to commercial development or mixed uses.

13%	23%	10%	25%	29%
Strongly Agree	Agree	Neutral	Disagree	Strongly Disagree

When land is developed in the Seagate area, the density (number of units per acre) of the project is more important than the architectural design.

13%	21%	6%	40%	19%
Strongly Agree	Agree	Neutral	Disagree	Strongly Disagree

Varied density residential uses support the need to supply housing to people of all income levels.

8%	37%	25%	19%	12%
Strongly Agree	Agree	Neutral	Disagree	Strongly Disagree

When land is developed in the Seagate area, higher densities should be allowed in exchange for increased environmental protection and/or public space.

10%	31%	17%	19%	23%
Strongly Agree	Agree	Neutral	Disagree	Strongly Disagree

Architectural design within some sections of the Seagate area warrants the need for design regulations to be adopted.

33%	40%	12%	15%	0%
Strongly Agree	Agree	Neutral	Disagree	Strongly Disagree

The Seagate area should form a cohesive neighborhood association, with staying power and political wherewithal.

42%	31%	17%	4%	6%
Strongly Agree	Agree	Neutral	Disagree	Strongly Disagree

***Though the community input process, staff recognized that there was confusion surrounding the difference between zoning and Future Land Use Plan designation, therefore, this question has been disregarded.

Appendix G—Growth and Redevelopment Factors - Results

The following is a list of factors commonly associated with growth and redevelopment in transitioning residential areas. Please rank them relative to each other in terms of **importance to planning the future of your community** (with 1 being the **most** important and 9 being the **least** important) **using each number only once.**

- 1 Stormwater management (flooding, runoff, impervious surface coverage)
- 2 Environmental impact (water quality, open space)
- 3 Density (number of housing units per acre)
- 4 Quality (building materials, site design)
- 5 Context (compatibility with existing housing types and designs)
- 6 Availability of adequate roads, schools, police and fire protection, water, sewer and parks
- 7 Fiscal impact (cost/benefit: infrastructure costs vs. increase in tax base)
- 8 Commercial intrusion (commercial uses moving in from periphery of residential areas)
- 9 Affordable housing

Note: A total of 52 citizens participated in this exercise. Each factor received a ranking from each participant, indicating the importance of each factor to the future of the Seagate community. Results are based on the average ranking received for each growth and redevelopment factor. Factors are listed in the order of the ranking they received.

Appendix H - Additional Resources

City of Wilmington Service Resources

www.wilmingtonnc.gov

Development Services (Planning, Zoning)	910.254.0900
Code Enforcement (Junk Vehicles, Public Nuisance, etc)	910.341.3266
Police (Non-Emergency)	910.343.3610
Solid Waste Management	910.341.7875
Stormwater Services	910.343.4777
Traffic Engineering	910.341.7888
Information & Assistance	910.341.7800

Neighborhood Resources

Neighborhood Planning

www.neighborhoodplanning.org

Neighborhoods USA

www.nusa.org

City of Wilmington Community Development (Community Development Block Grants, HOME Funds, etc)

www.wilmingtonnc.gov

910.341.7836

Density in Your Backyard (100 Friends of Oregon)

www.friends.org/index.html

Historic Preservation Resources

Historic Wilmington Foundation (Plaque Program)

www.historicwilmington.org

910.762.2511

City of Wilmington Historic Preservation Planner, Development Services Department (Nomination of local landmarks)

www.wilmingtonnc.gov

910.341.3251

NC State Historic Preservation Office (Historical Markers and Signs)
www.hpo.dcr.state.nc.us
919.733.4763

North Carolina Room, New Hanover County Library
<http://www.nhcgov.com/AgnAndDpt/LIBR/LocalHistory/Pages/default.aspx>
910.798.6300

Environmental Protection Resources

Bradley Creek Preservation Society of North Carolina
<http://home.ec.rr.com/preservecreeks/preservecreeks.html>

New Hanover County Tidal Creeks Program
www.uncwil.edu/cmsr/aquaticceology/TidalCreeks/Index.htm

UNCW Center for Marine Science
www.uncw.edu/msr
910.962.2301

North Carolina Division of Water Quality
www.h2o.enr.state.nc.us
919.733.7015

City of Wilmington Environmental Planner, Development Services Department
910.342.2779

New Hanover County Soil and Water Conservation District
www.nhswcd.org

US Environmental Protection Agency – Green Building
<http://www.epa.gov/greenbuilding>

US Green Building Council
<http://www.usgbc.org>